



SIDEKICKS - REFRIGERATOR



Model 5VEL88TRAS

Specifications:

Net (inches): H 66.6 x W 30 x D 31 (28 ½ w/o handle)
 Net (cm): H 169 x W 76.2 x D 78.7
 Carton (inches): H 69 3/8 x W 32 ¼ x D 30 ¼
 Voltage: 220-240 Volt ~50/60 Hertz
 Gross Weight: 92.5 kg/ 204 lbs

Model 5VEL88TRAS

Features:

- 18 Cu.Ft Capacity All-Refrigerator
- Stainless Steel Finish
- Flat Smooth Door with Brushed Aluminum Handle
- Right Swing Door
- R134a Refrigerant
- Automatic Defrost System
- Up-Front Temperature Controls
- Five Adjustable Slide-out **SPILL GUARD™** Glass Shelves
- Two Clear **EZ VUE™** Humidity-Controlled Crispers
- Half-Width Clear Meat Crisper
- 6 Adjustable Door Bins
- Covered Clear Dairy Door Bin
- One Gallon Lower Door Bin
- Egg Tray
- Refrigerator Light
- Energy Efficient Product 2015 (Whirlpool R2345)
- CE/UL rated
- 2 Front Adjustable Legs and 2 Rollers (back)
- Climate Class T
- Matching Upright Freezer 5VEV188NAS
- Optional Trim Kit **SKT60S** (includes A to I) or Finishing Kit **SKFK60S** (includes E, F, G & I)

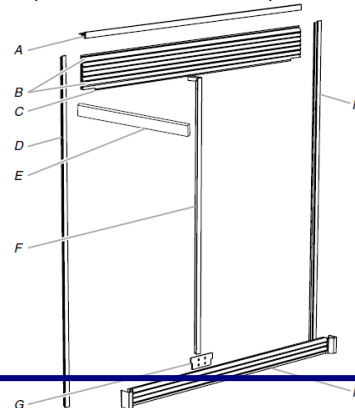

A Job Well Done™

Distributed by Piraeus International, Inc